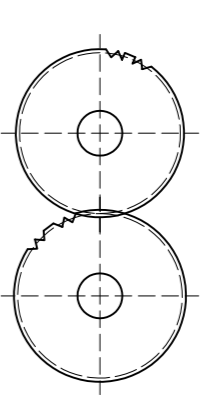
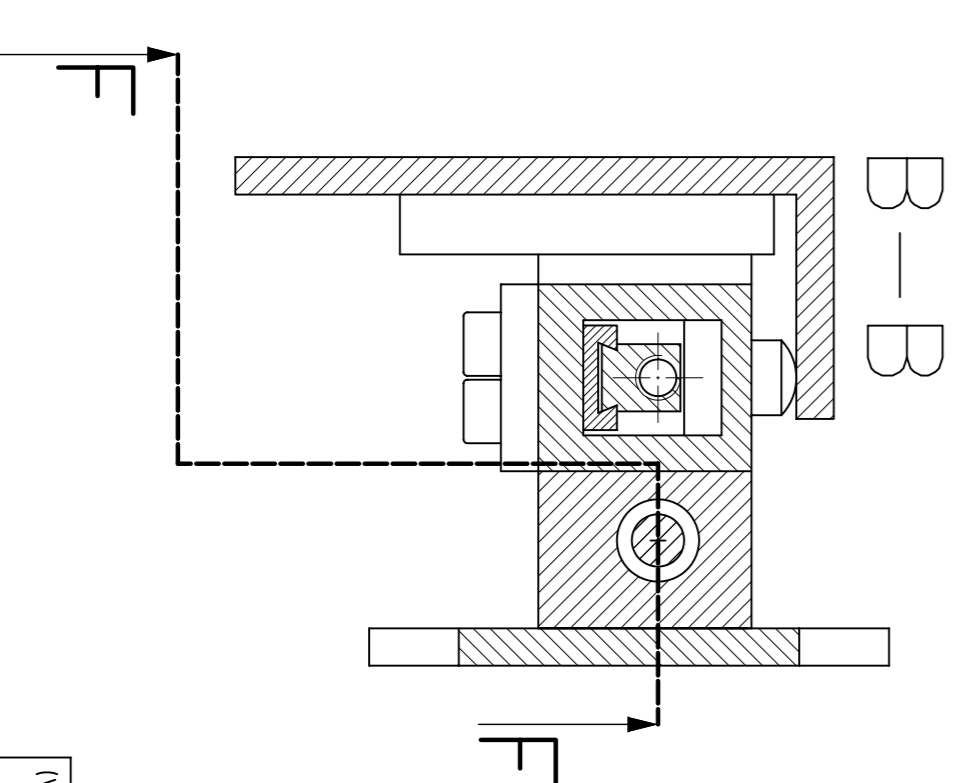
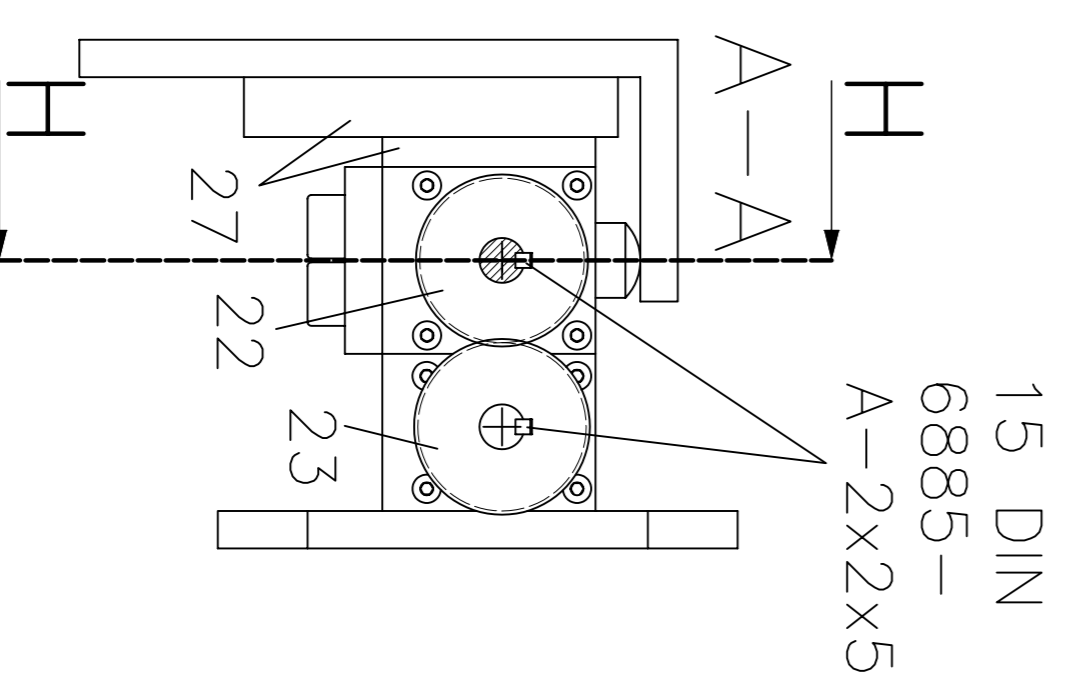
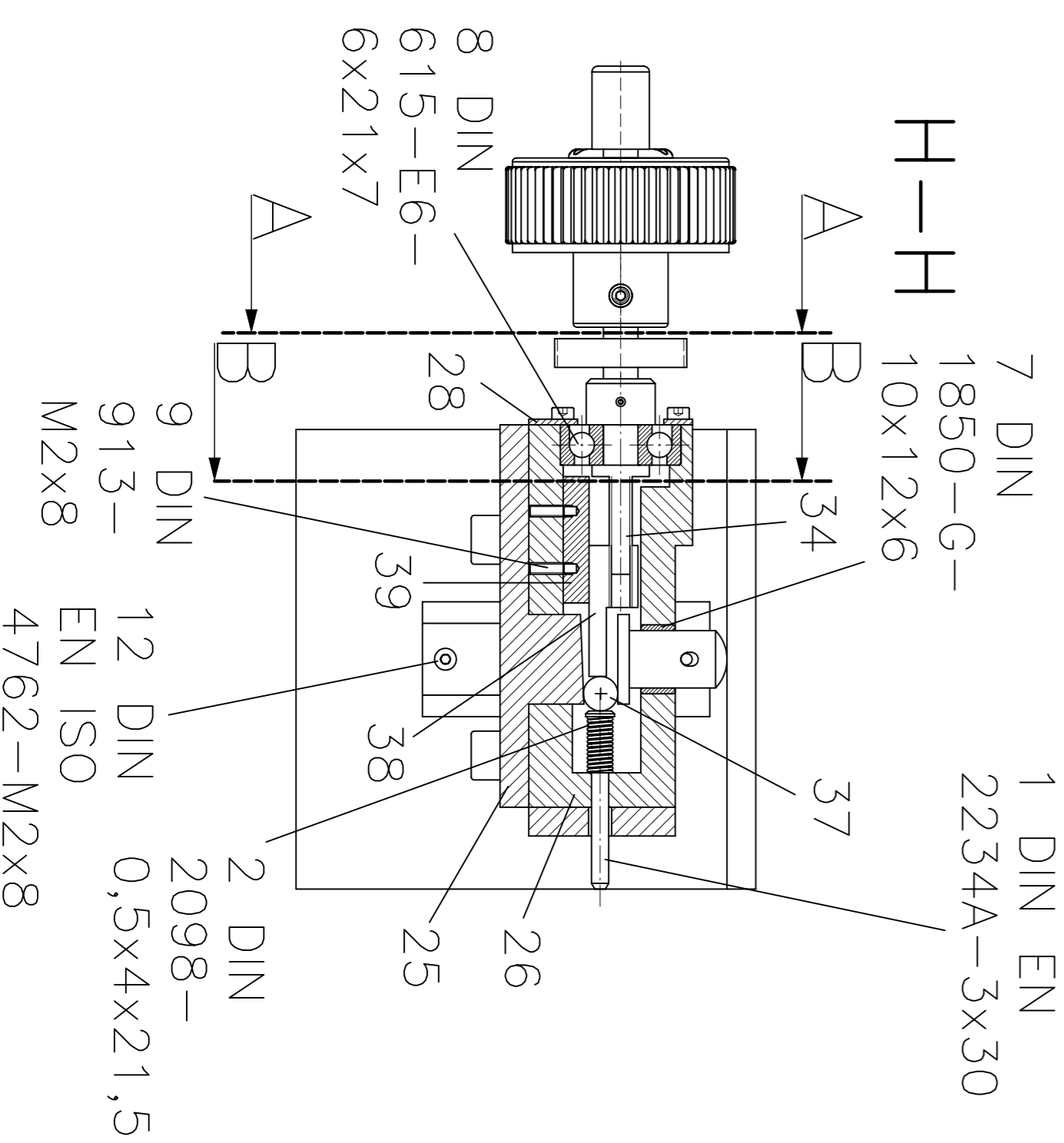
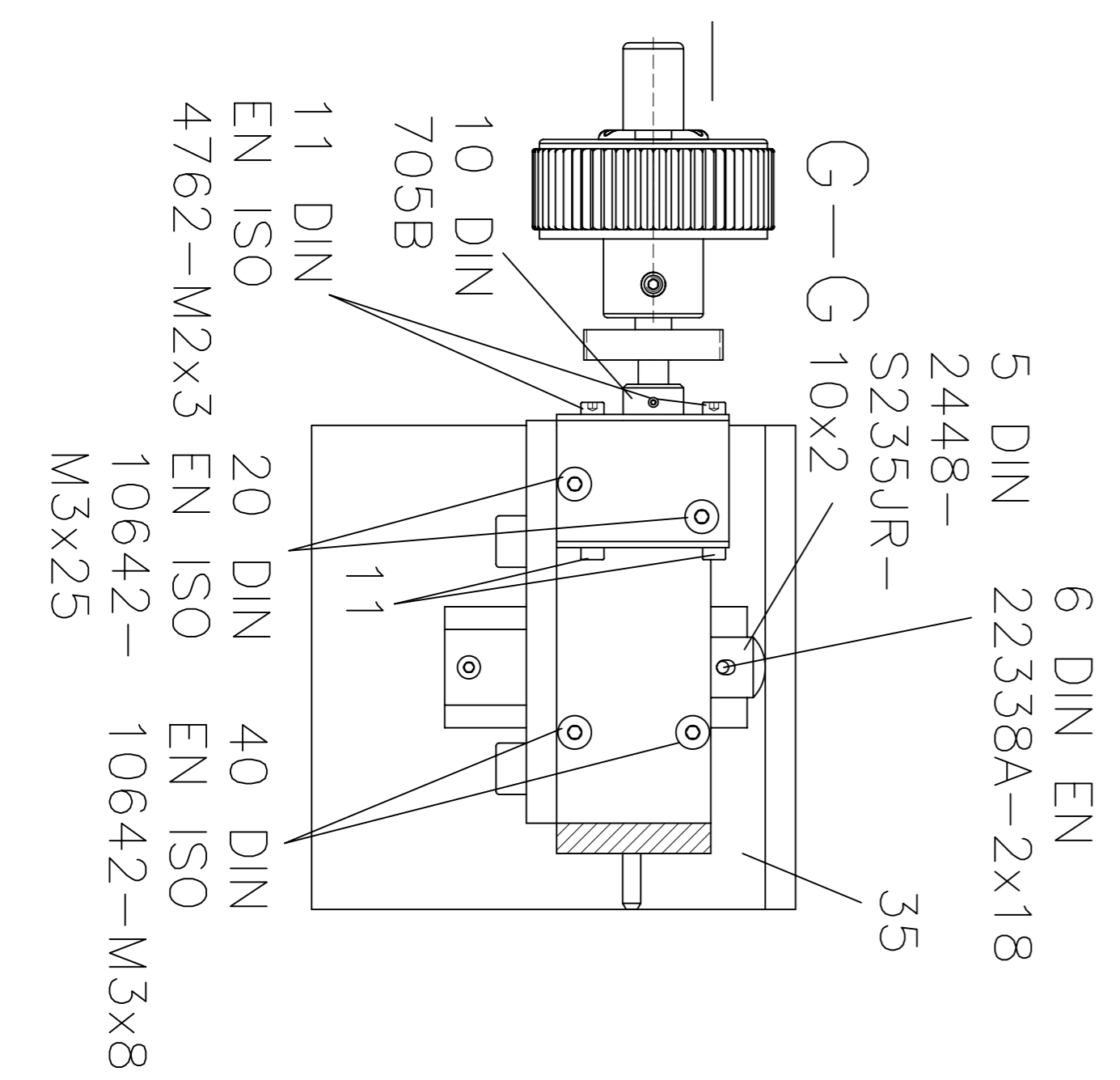
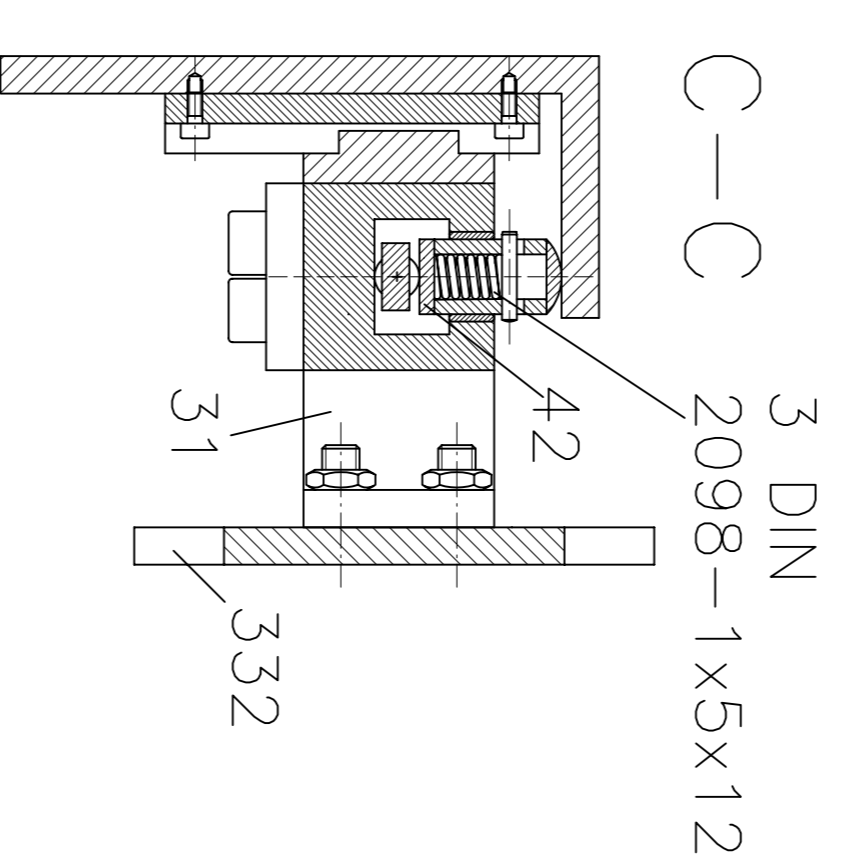
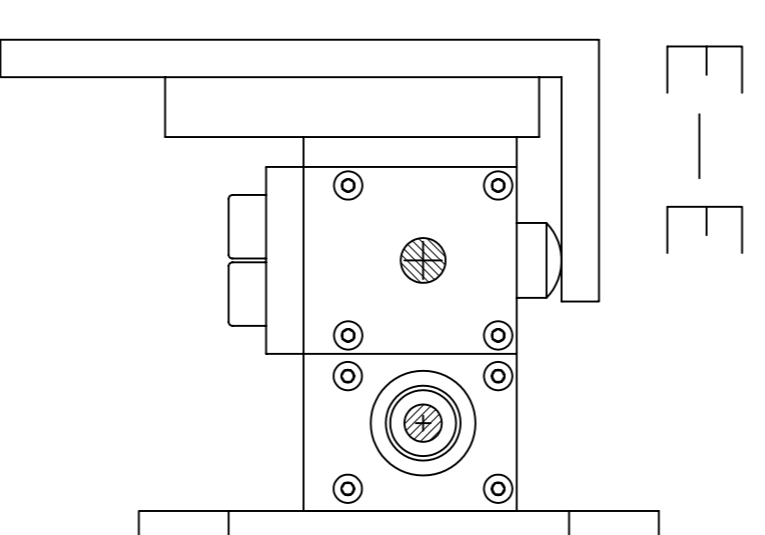
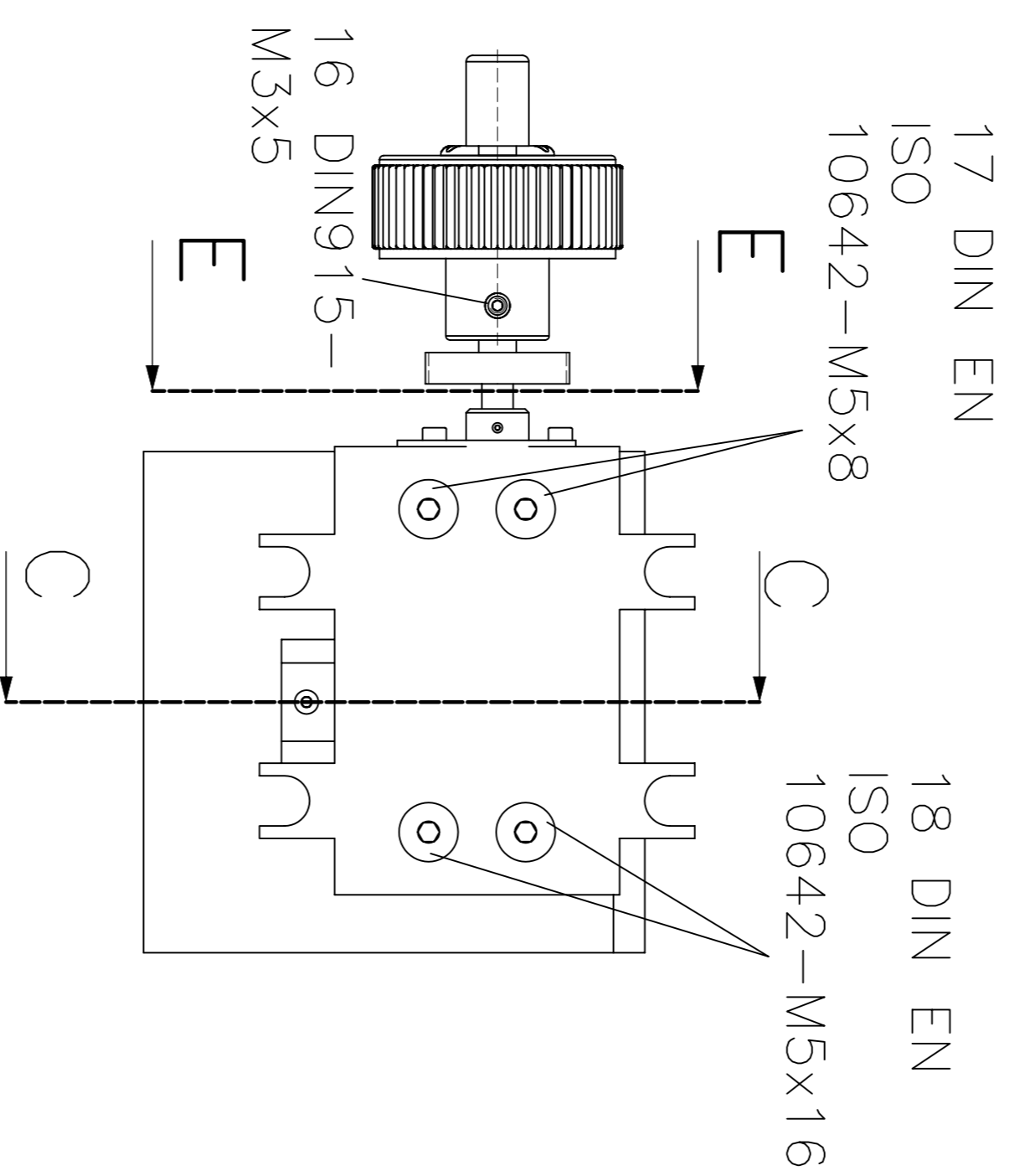
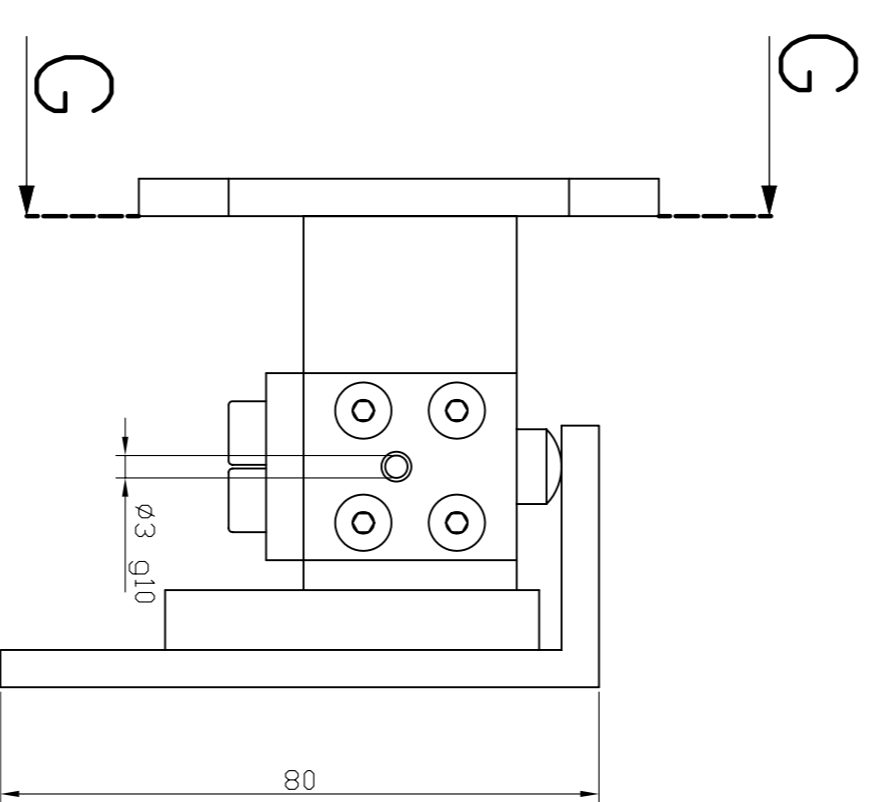
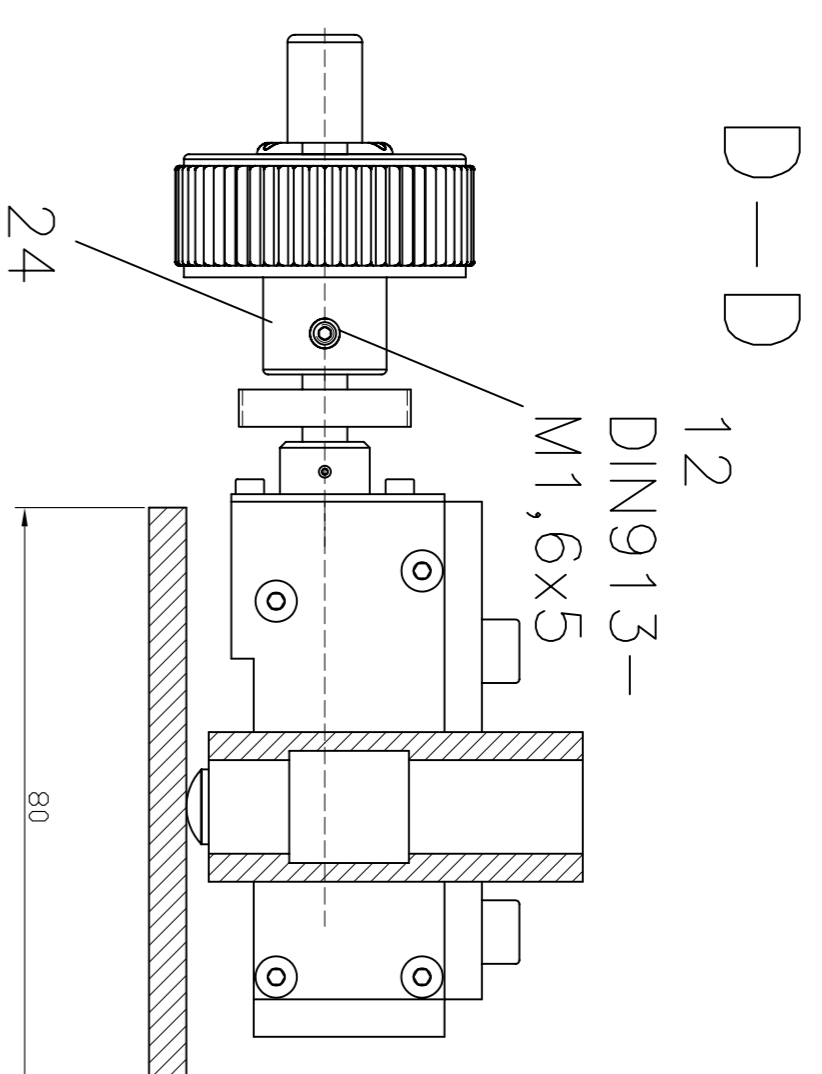
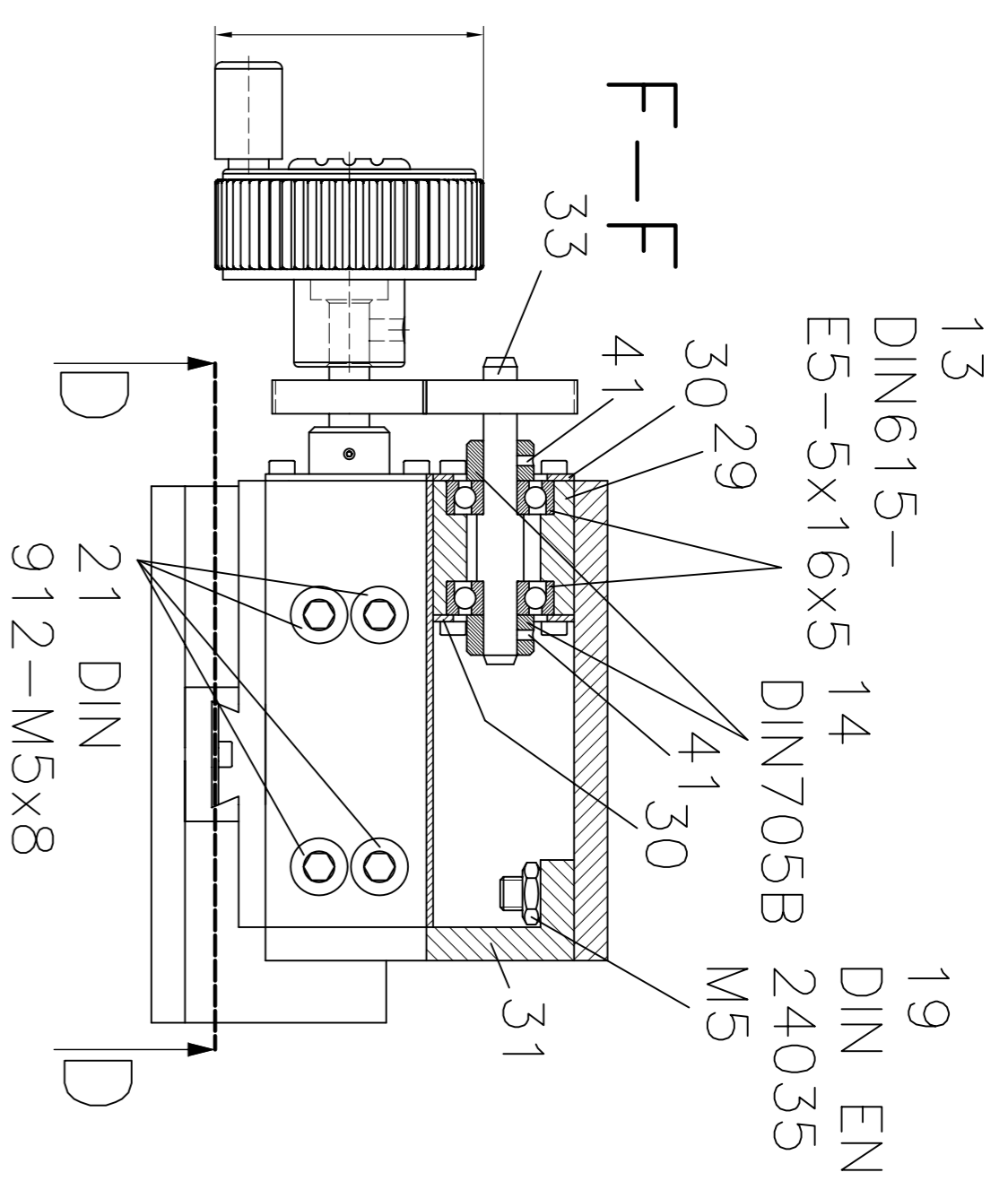

Bimzelteil-
zeichnung
Zahnräder

(Verwendungsbereich)		(Zu: Abw.)		(Oberfl.)		(Maßstab 1:1)		(Gewicht)	
Allgemein- toleranz 2768-F		Datum 12.07.04		Name H.KLEINKE		Modultab 11		[Gezeichnet] Hahnbau] 34C-Mc4 DIN EN 10083	
Bearb. Norm		Datum		Name		Modell- oder Gesenk-Nr.		MESSTISCH	
Zust.		Änderung		Datum		Name/ Ursprung		Ersatz für:	
								Ersatz durch:	
								Blatt 6	
								Blätter	